



# INSTALLATION INSTRUCTIONS

Accessory

17" ALUMINUM WHEEL  
P/N 08W17-TX6-200

Application

2015 ILX

Publications No.

BII 51682

Issue Date

MAY 2014

## PARTS LIST

Aluminum wheel  
(The illustration may differ from the actual wheel.)



Wheel center cap



## Parts for TPMS sensor assembly

Tire pressure sensor assembly

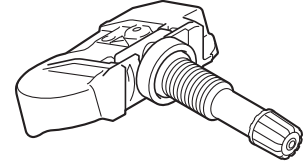

Washer



Valve nut



## TOOLS AND SUPPLIES REQUIRED

Ratchet

11 mm and 19 mm Sockets

Torque wrench

HDS

*The following tool is available through the Honda Tool and Equipment Program. On the iN, click on: Service > Service Bay > Tool and Equipment Program, then enter the number under "Search". Or, call 888-424-6857.*

- TPMS Trigger Tool (T/N AEQVT55)

## INSTALLATION

**Client Information:** The information in this installation instruction is intended for use only by skilled technicians who have the proper tools, equipment, and training to correctly and safely add equipment to your vehicle. These procedures should not be attempted by “do-it-yourselfers.”

### NOTE:

- This aluminum wheel is designed for use on a vehicle equipped with a TPMS (Tire Pressure Monitoring System).
- This aluminum wheel is equipped with a TPMS sensor. See the service manual for the tire replacement and TPMS sensor installation procedures.
- The illustrations of the aluminum wheels are shown for reference purposes only.
- Install the correct size tire.
- Follow the instructions in the owner's manual when raising the vehicle, and when removing and installing the wheels. Do not overtighten the wheel nuts. Wheel nut torque: 108 N·m (11 kgf·m, 80 lbf·ft).
- Use a tire changer to install and remove the tires per the directions in the Operation Manual furnished with the tire changer. Do not use a tire lever to install and remove the tires as it may cause damage to the tire and aluminum wheel.

1. Before installing the tire pressure sensor, clean the mating surface on the sensor and the aluminum wheel.

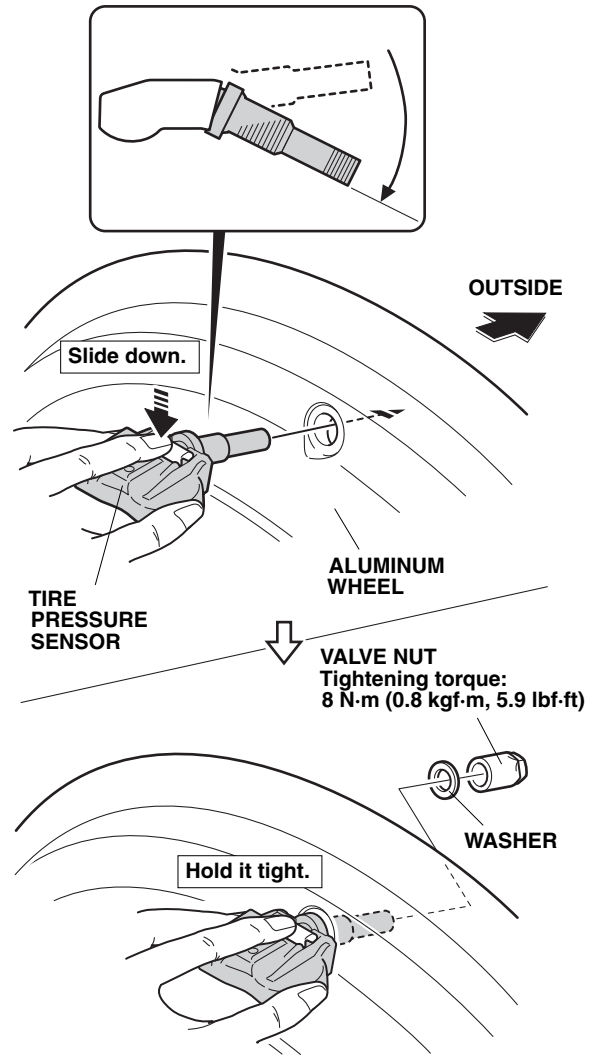

930403AR

2. Install the tire pressure sensor and the washer on the aluminum wheel, and tighten the valve nut finger tight. Make sure the pressure sensor is resting on the wheel.
3. While holding the tire pressure sensor against the wheel, tighten the valve nut to the specified torque. Tightening torque: 8 N·m (0.8 kgf·m, 5.9 lbf·ft)

**NOTE:**

- Check the grommet on the tire pressure sensor to make sure it is seated properly.
- Make sure the valve stem does not protrude into the sensor housing surface.
- To prevent the sensor housing from getting caught on the bead of the tire, install the tire pressure sensor so that the sensor housing does not protrude into the bead area of the wheel.
- Do not reuse a grommet that had been tightened, even one time, to the specified torque, as it is deformed inside.
- Do not use pneumatic or electric tools on the valve nut.
- Tightening the nut above the specified torque can damage the grommet.

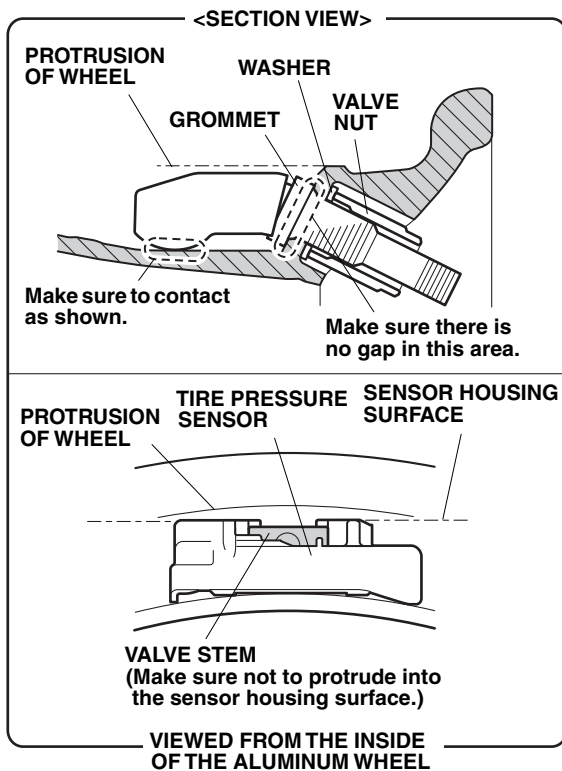

930404BR

4. Install the tires according to the instructions in the service manual.
5. Install the wheels on the vehicle and torque to 108 N·m (11 kgf·m, 80 lbf·ft).

**Memorizing the Tire Pressure Sensor ID**

6. Using the HDS and the TPMS trigger tool, memorize the tire pressure sensor ID. Follow the instructions in the service manual.

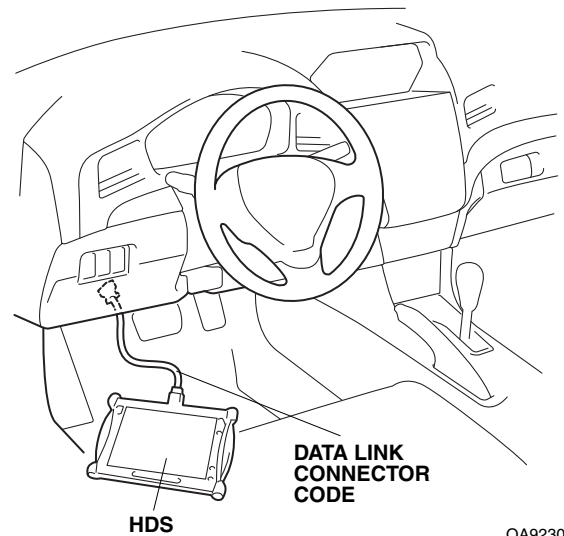

QA92301AJ

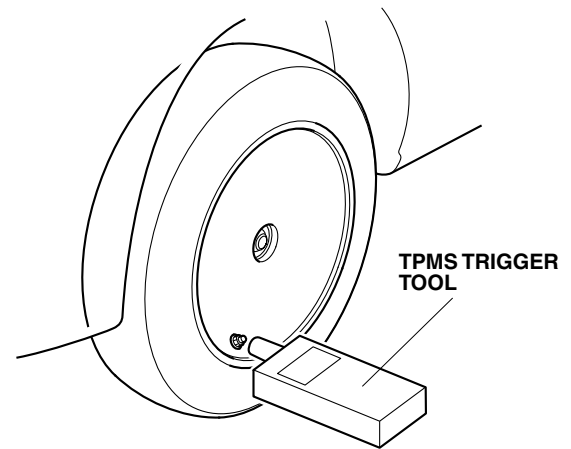

062101A

**USE AND CARE**

- Use a neutral detergent to clean the wheels.
- Rinse off the neutral detergent promptly after cleaning the wheels.